

Colour combination - Valde

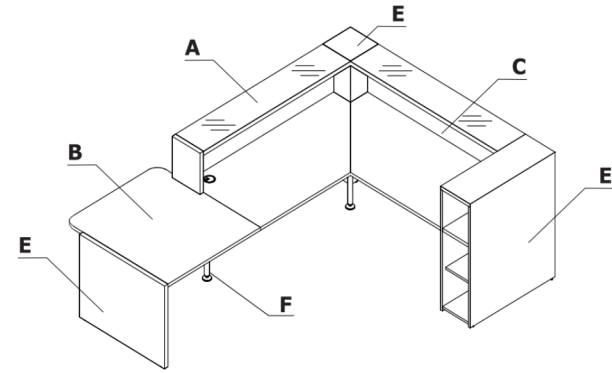
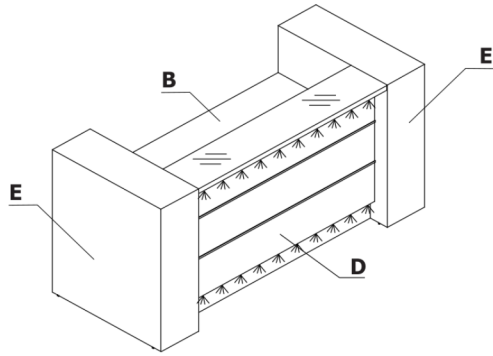

Material	Colour	All elements					Complementary elements								
		A - Upper top	B - Top	C - Body	D - Front	E - Ending elements	F - Supporting legs	LAD10, LMS05, LMS06	S69L, E64L	S81L					
Glass	117 - glass white	✓	67 - white pastel												
	124 - glass silver	✓	26 - aluminum satinato												
MFC	26 - aluminum satinato		✓					✓							
	67 - white pastel		✓	✓				✓							
HPL	31 - canadian oak				✓										
	34 - chestnut				✓										
	73 - white high gloss				✓	✓									
	74 - orange high gloss				✓										
	80 - green high gloss				✓										
	81 - burgundy high gloss				✓										
	102 - yellow high gloss				✓										
	108 - blue high gloss				✓										
	127 - dark pink high gloss				✓										
	148 - grey high gloss				✓	✓									
Metal	Metal - M009 - aluminum semi-mat							✓		✓					
	Metal - M015 - white semi-mat							✓							
	Polyurethane - grey									✓					

Technical specification

- 1 Top** - MFC 36 mm + Glass LACOBEL 4 mm (40 mm)
- 2 Worktop** - MFC 28 mm, ABS edge
- 3 Decorative stripe** - PVC, colour: M009 - aluminium semi-matt
- 4 Front** - HPL 3 mm - high gloss
- 5 Storage as ending element** - HPL high gloss 18 mm, ABS edge
- 6 LED illumination** - at the full length of the reception desk, cold white color (verging on the blue shade);
- 7 Kick plate** - HPL - brushed aluminium
- 8 Leveling** - 5 mm range

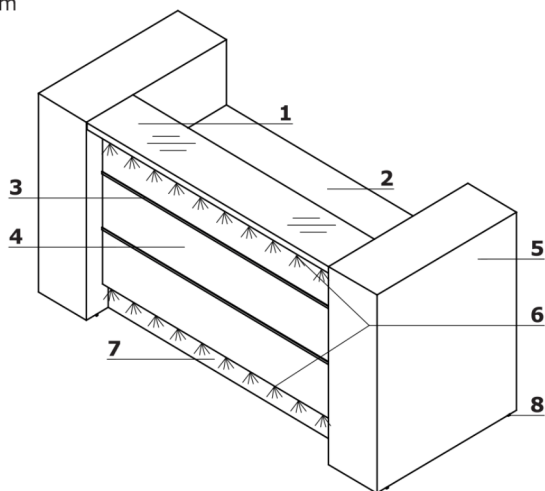

Technical specification

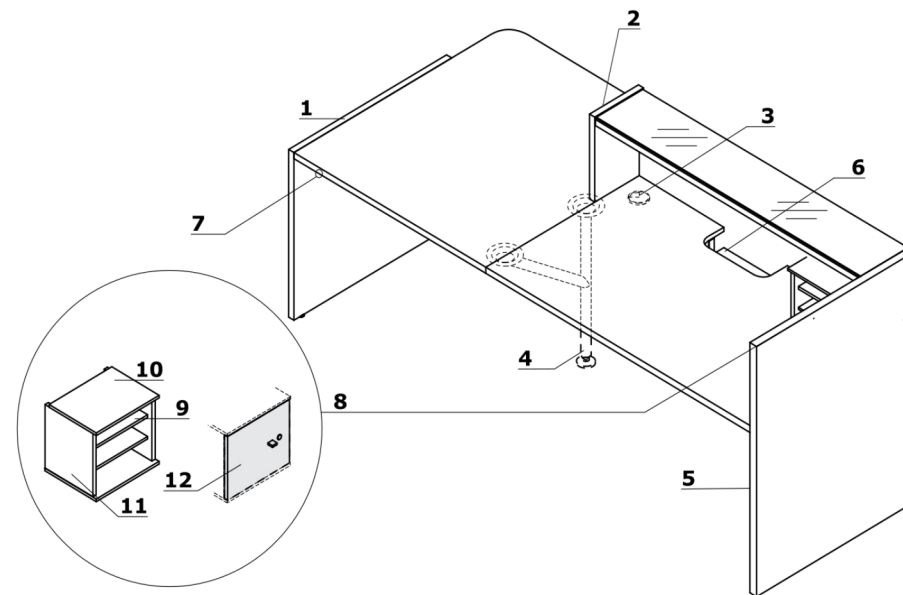

ATTENTION - Interior of the front in white

- 1 Low side panel** - HPL high gloss - 38 mm
- 2 Side panel linking low and high fronts** - HPL high gloss - 38 mm
- 3 Cable grommets** - Ø80 mm
- 4 Supporting leg NE41** - made of metal, required for tops connecting, colours: M015 - white semi-matt, M009 - Aluminum semi-matt, colour adjusted to the colour of worktop
- 5 High side panel** - HPL high gloss - 38 mm
- 6 OPTION WITH EXTRA CHARGE** - working top with lowered monitor shelf - MFC 28 mm, ABS edge
- 7 Light switch**
- 8 LMS05** - reception desk storage; order separately
- 9 Shelf** - MFC 18 mm, protection against accidental falling-out, ABS edge
- 10 Top** - MFC 12 mm, ABS edge
- 11 Body** - MFC 18 mm, ABS edge
- 12 Optional front with lock** - universal (left, right); - MFC 18 mm, ABS edge; - ordered as separate element

Ending storage

- 1 Storage as ending element** - HPL high gloss 18 mm, ABS edge
- 2 Leveling** - 5 mm range
- 3 Shelf** - MFC 28 mm, ABS edge
- 4 Shelf with possibility of height regulation** - MFC 18 mm, ABS edge
- 5 Base** - MFC 18 mm, ABS edge
- 6 Optional Front LAD10** - MFC 18 mm, universal (left/right);, to order as an additional element
- 7 Patent lock** - foldable key

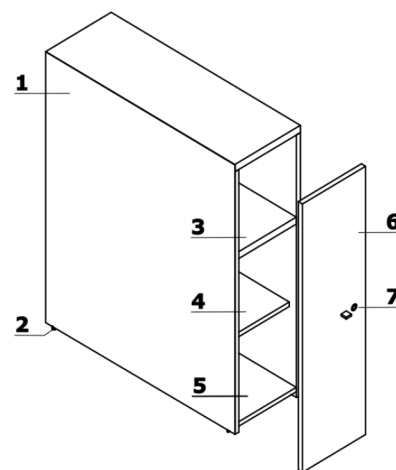

Ending elements application

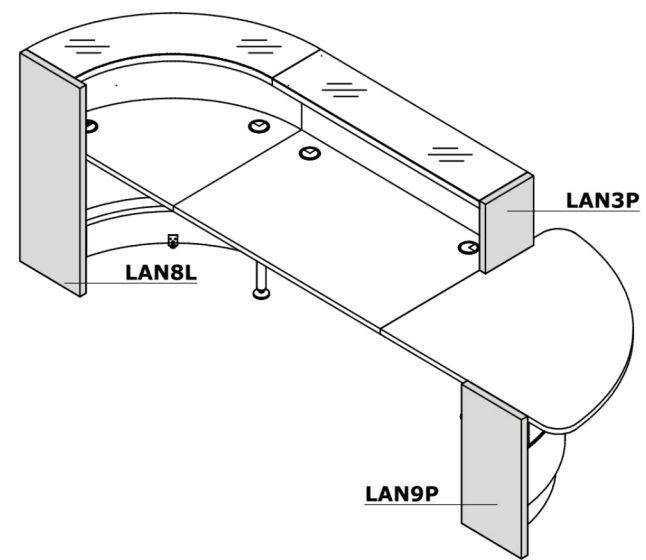
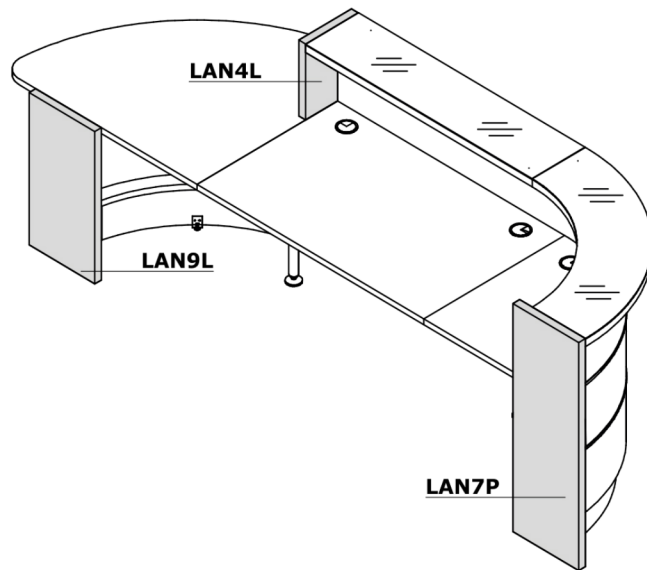
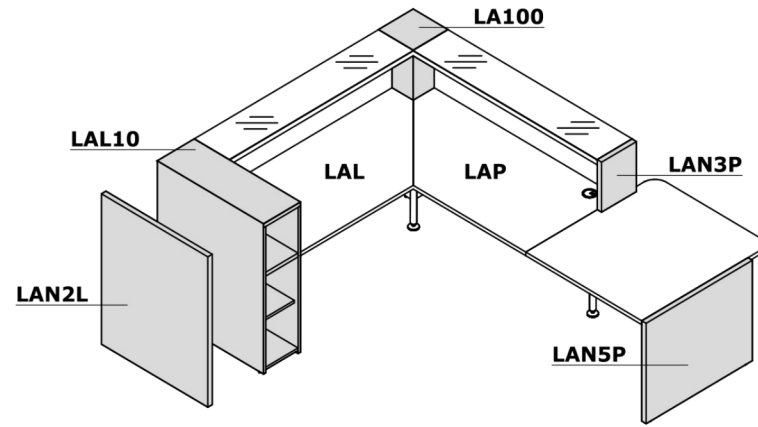
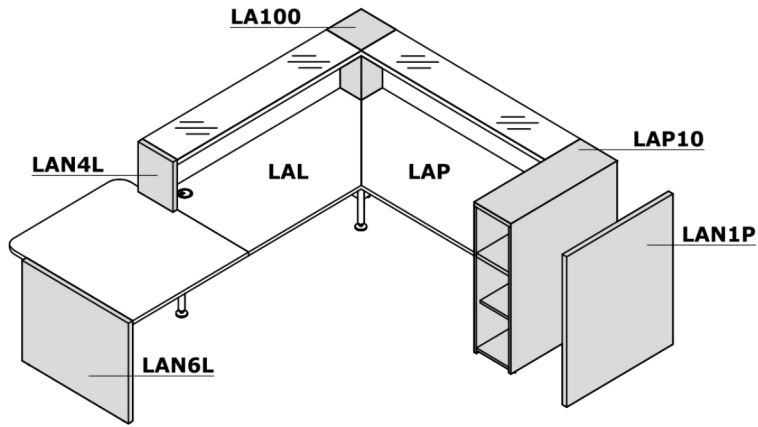

Dimensions

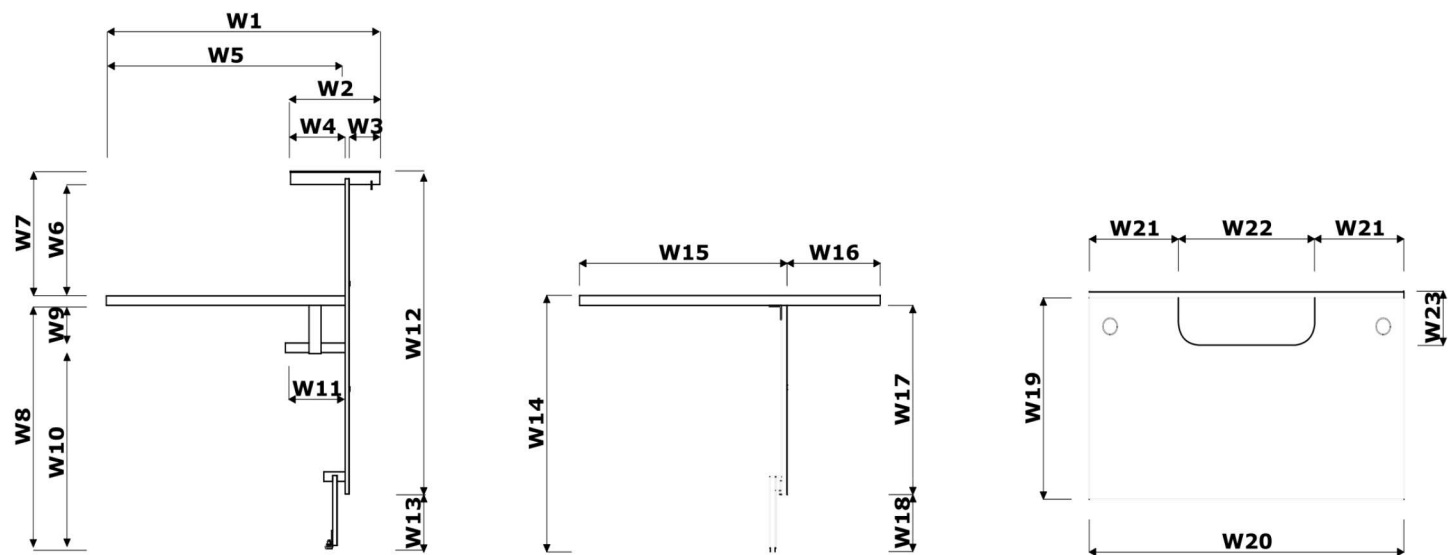

W1 - 916 mm | W2 - 300 mm | W3 - 103 mm | W4 - 183 mm | W5 - 800 mm | W6 - 324 mm | W7 - 364 mm | W8 - 712 mm | W9 - 110 mm | W10 - 574 mm | W11 - 200 mm |
W12 - 944 mm | W13 - 150 mm | W14 - 740 mm | W15 - 814 mm | W16 - 300 mm | W17 - 580 mm | W18 - 160 mm | W19 - 800 mm | W20 - 1290/1590/2290 mm |
W21 - 385/535/885 mm | W22 - 520 mm | W23 - 200 mm |

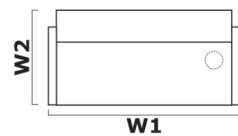
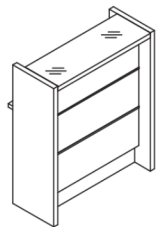

Symbol		Dimensions					kg m3 pcs	Composition elements
		W1	W2	D1	D2	H		
LAV96L		920	454	1622	850	1105	50.5 kg 0.178 m3 5 pcs	

Extra charge						

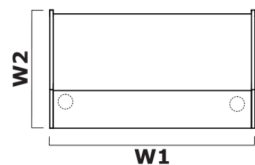
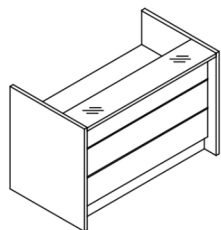

Symbol		Dimensions					kg m3 pcs	Composition elements
		W1	W2	D1	D2	H		
LAV95L		920	917	1622	850	1105	88 kg 0.252 m3 6 pcs	
LAV75L		1366	917	1622	850	1105	105.6 kg 0.326 m3 6 pcs	
LAV76L		1666	917	1622	850	1105	119 kg 0.373 m3 6 pcs	
LAV77L		2366	917	1622	850	1105	145.5 kg 0.497 m3 7 pcs	

Extra charge						
Monitor shelf x1						
X						
X						
X						

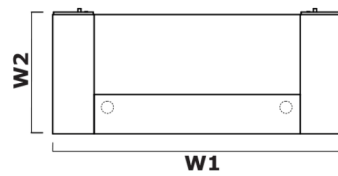
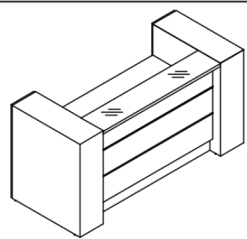

Symbol		Dimensions					kg m3 pcs	Composition elements
		W1	W2	D1	D2	H		
LAV01L		1926	937	1622	850	1105	162.6 kg 0.973 m3 8 pcs	
LAV02L		2226	937	1622	850	1105	176 kg 1.02 m3 8 pcs	
LAV03L		2926	937	1622	850	1105	202.5 kg 1.145 m3 9 pcs	

Extra charge						
Monitor shelf x1						
X						
X						
X						

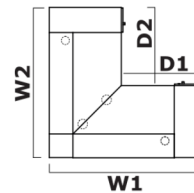
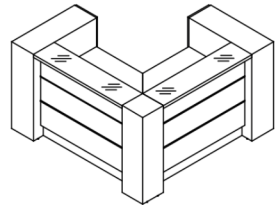

Symbol		Dimensions					kg m3 pcs	Composition elements
		W1	W2	D1	D2	H		
LAV10L		1908	1908	991	991	1105	238.4 kg 1.374 m3 14 pcs	
LAV11L		1908	2208	991	1291	1105	252.3 kg 1.421 m3 14 pcs	
LAV12L		1908	2908	991	1991	1105	278.8 kg 1.546 m3 15 pcs	
LAV13L		2208	1908	1291	991	1105	252.3 kg 1.421 m3 14 pcs	
LAV14L		2208	2208	1291	1291	1105	266.2 kg 1.468 m3 14 pcs	
LAV15L		2208	2908	1291	1991	1105	292.7 kg 1.593 m3 15 pcs	

Extra charge						
Monitor shelf x1	Monitor shelf x2					
X	X					
X	X					
X	X					
X	X					
X	X					

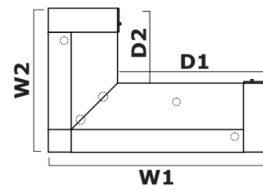
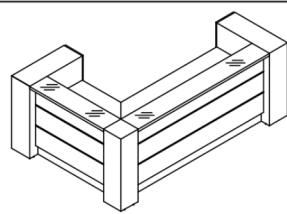

Symbol		Dimensions					kg m3 pcs	Composition elements
		W1	W2	D1	D2	H		
LAV16L		2908	1908	1991	991	1105	278.8 kg 1.546 m3 15 pcs	
LAV17L		2908	2208	1991	1291	1105	292.7 kg 1.593 m3 15 pcs	
LAV18L		2908	2908	1991	1991	1105	319.2 kg 1.717 m3 16 pcs	

Extra charge						
Monitor shelf x 1	Monitor shelf x 2					
X	X					
X	X					
X	X					

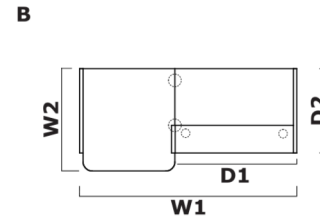
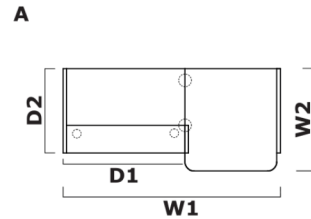
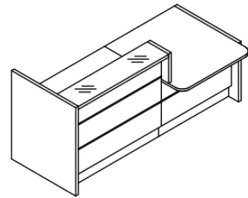

Symbol		Dimensions					kg m3 pcs	Composition elements
		W1	W2	D1	D2	H		
LAV19L	LAV20L	2366	1114	1328	917	1105	138.9 kg 0.509 m3 12 pcs	A - B -
LAV21L	LAV22L	2666	1114	1628	917	1105	152.3 kg 0.556 m3 12 pcs	A - B -
LAV23L	LAV24L	3366	1114	2318	917	1105	178.8 kg 0.68 m3 13 pcs	A - B -
LAV191L	LAV201L	2166	1114	1328	917	1105	134.9 kg 0.486 m3 12 pcs	A - B -
LAV211L	LAV221L	2466	1114	1628	917	1105	148.3 kg 0.533 m3 12 pcs	A - B -
LAV231L	LAV241L	3166	1114	2318	917	1105	174.8 kg 0.657 m3 13 pcs	A - B -

Extra charge						
Monitor shelf x 1						
X						
X						
X						
X						
X						

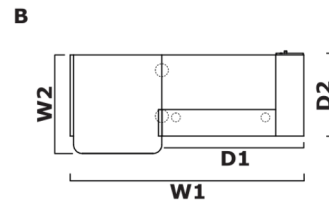
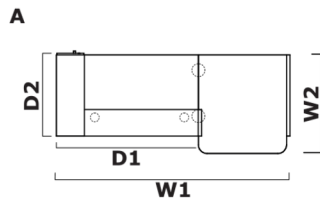
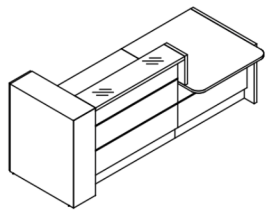

Symbol			Dimensions					kg m3 pcs	Composition elements
A	B		W1	W2	D1	D2	H		
LAV41L	LAV42L		2646	1134	1608	937	1105	167.4 kg 0.833 m3 13 pcs	A - B -
LAV43L	LAV44L		2946	1134	1908	937	1105	180.8 kg 0.88 m3 13 pcs	A - B -
LAV45L	LAV46L		3646	1134	2608	937	1105	207.3 kg 1.004 m3 14 pcs	A - B -
LAV411L	LAV421L		2446	1134	1608	937	1105	163.4 kg 0.809 m3 13 pcs	A - B -
LAV431L	LAV441L		2746	1134	1908	937	1105	176.8 kg 0.856 m3 13 pcs	A - B -
LAV451L	LAV461L		3446	1134	2608	937	1105	203.3 kg 0.981 m3 14 pcs	A - B -

Extra charge						
Monitor shelf x1						
X						
X						
X						
X						
X						
X						

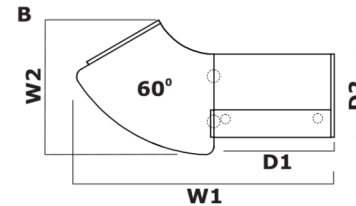
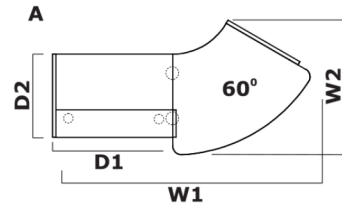
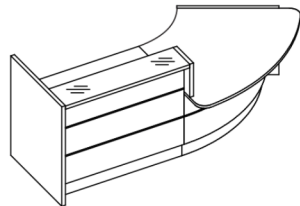

Symbol			Dimensions					kg m3 pcs	Composition elements
A	B		W1	W2	D1	D2	H		
LAV88L	LAV89L		2845	1486	1328	917	1105	160.9 kg 0.832 m3 12 pcs	A - B -
LAV91L	LAV92L		3145	1486	1628	917	1105	174.3 kg 0.879 m3 12 pcs	A - B -

Extra charge						
Monitor shelf x1						
X						
X						

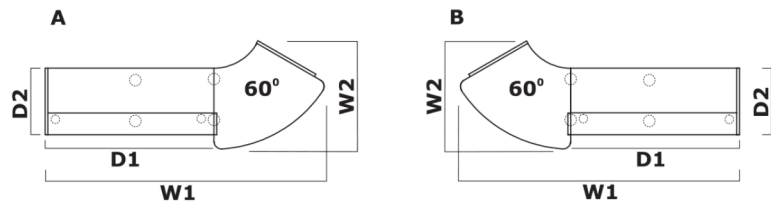
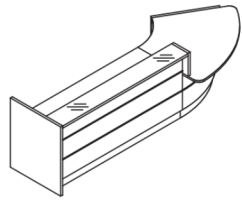

Symbol			Dimensions					kg m3 pcs	Composition elements
A	B		W1	W2	D1	D2	H		
LAV93L	LAV94L		3845	1486	2318	917	1105	200.8 kg 1.003 m3 13 pcs	A - B -

Extra charge					
Monitor shelf x1					
X					

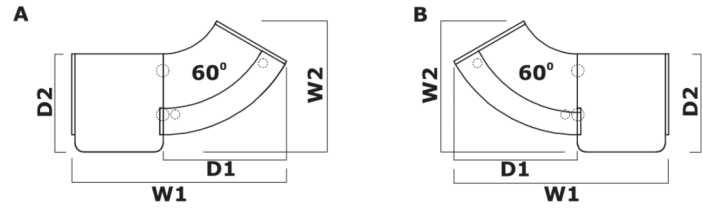
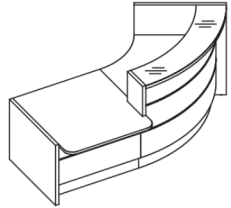

Symbol			Dimensions					kg m3 pcs	Composition elements
A	B		W1	W2	D1	D2	H		
LAV84L	LAV85L		2443	1489	1404	1114	1105	149.8 kg 0.957 m3 12 pcs	A - B -
LAV841L	LAV851L		2243	1489	1404	1114	1105	145.8 kg 0.934 m3 12 pcs	A - B -

Extra charge					
Monitor shelf x1					
X					
X					

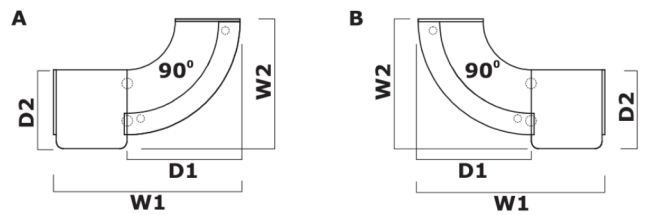
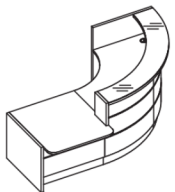

Symbol			Dimensions					kg m3 pcs	Composition elements
A	B		W1	W2	D1	D2	H		
LAV86L	LAV87L		2638	1835	1600	937	1105	190.8 kg 1.328 m3 13 pcs	A - B -
LAV861L	LAV871L		2438	1835	1600	937	1105	186.8 kg 1.305 m3 13 pcs	A - B -

Extra charge					
Monitor shelf x1					
X					
X					

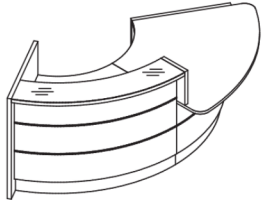

A

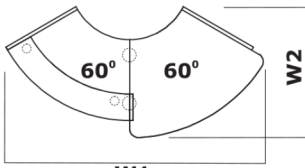

B

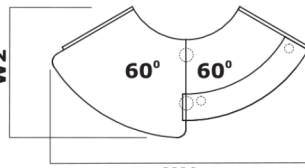

Symbol			Dimensions					kg m3 pcs	Composition elements
A	B		W1	W2	D1	D2	H		
LAV30L	LAV31L		2922	1486	1600	937	1105	171.8 kg 1.28 m3 12 pcs	A - B -

Extra charge						
Monitor shelf x1						
X						

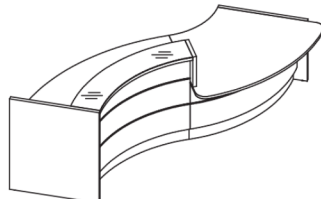

A

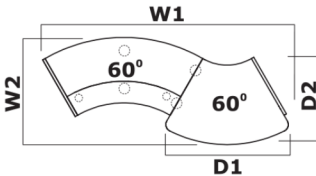

B

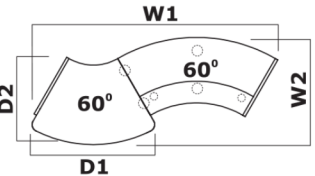

Symbol			Dimensions					kg m3 pcs	Composition elements
A	B		W1	W2	D1	D2	H		
LAV32L	LAV33L		3452	1502	1720	1225	1105	182.8 kg 1.366 m3 13 pcs	A - B -

Extra charge						
Monitor shelf x1						
X						

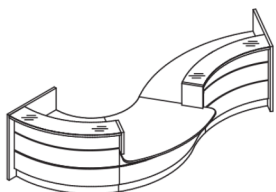

A

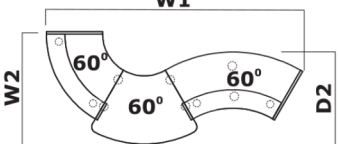

B

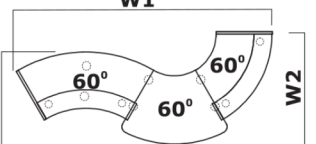

Symbol			Dimensions					kg m3 pcs	Composition elements
A	B		W1	W2	D1	D2	H		
LAV34L	LAV35L		4195	1835	0	1503	1105	262.1 kg 2.129 m3 20 pcs	A - B -

Extra charge						
Monitor shelf x1	Monitor shelf x2					
X	X					

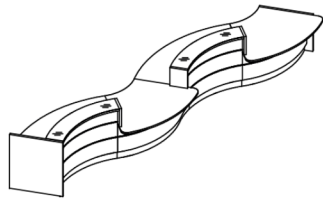
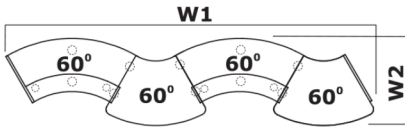
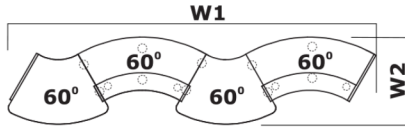
		A					B				
											
Symbol		Dimensions					kg m3 pcs	Composition elements			
A	B	W1	W2	D1	D2	H					
LAV36L	LAV37L	6352	1503	0	1503	1105	325.4 kg 2.715 m3 26 pcs	A - B -			

Extra charge					
Monitor shelf x1	Monitor shelf x 2				
X	X				

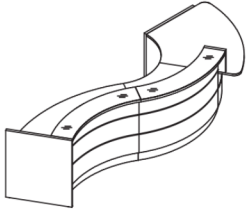
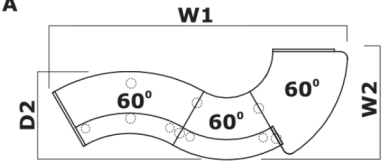
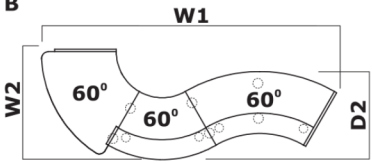
		A					B				
											
Symbol		Dimensions					kg m3 pcs	Composition elements			
A	B	W1	W2	D1	D2	H					
LAV38L	LAV39L	4386	1639	0	1307	1105	252.3 kg 2.106 m3 19 pcs	A - B -			

Extra charge					
Monitor shelf x1	Monitor shelf x 2				
X	X				

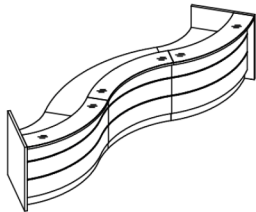
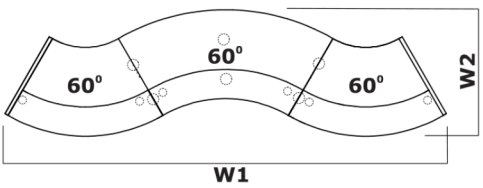
											
Symbol		Dimensions					kg m3 pcs	Composition elements			
A	B	W1	W2	D1	D2	H					
LAV50L		4566	1307	0	1307	1105	260.5 kg 2.329 m3 17 pcs				

Extra charge					
Monitor shelf x1	Monitor shelf x 2	Monitor shelf x 3			
X	X	X			

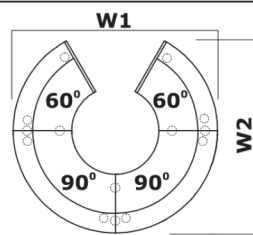
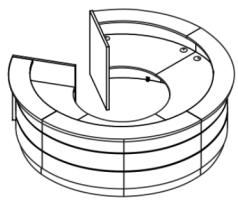

Symbol		Dimensions					kg m3 pcs	Composition elements
		W1	W2	D1	D2	H		
LAV51L		3202	3006	0	1307	1105	410 kg 3.741 m3 27 pcs	

Extra charge						
Monitor shelf x 1	Monitor shelf x 2	Monitor shelf x 3	Monitor shelf x 4			
X	X	X	X			

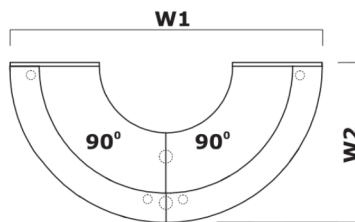
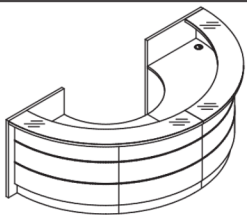

Symbol		Dimensions					kg m3 pcs	Composition elements
		W1	W2	D1	D2	H		
LAV52L		3202	1639	0	1307	1105	271 kg 2.261 m3 15 pcs	

Extra charge						
Monitor shelf x 1	Monitor shelf x 2					
X	X					

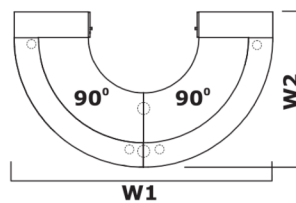
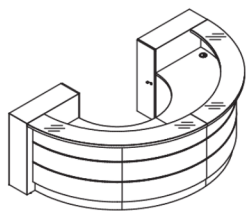

Symbol		Dimensions					kg m3 pcs	Composition elements
		W1	W2	D1	D2	H		
LAV61L		3202	1919	0	1307	1105	322 kg 2.898 m3 15 pcs	

Extra charge						
Monitor shelf x 1	Monitor shelf x 2					
X	X					

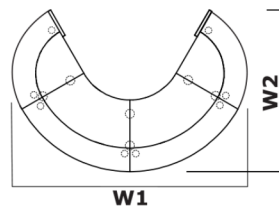
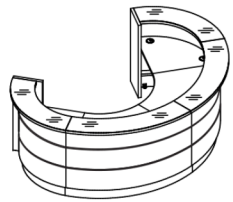

Symbol		Dimensions					kg m3 pcs	Composition elements
		W1	W2	D1	D2	H		
LAV04L		3202	3006	0	1307	1105	250 kg 2.312 m3 23 pcs	

Extra charge						
Monitor shelf x 1	Monitor shelf x 2					
X	X					

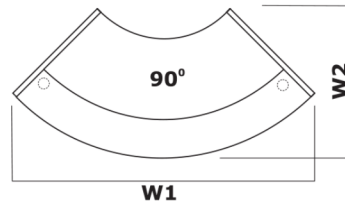
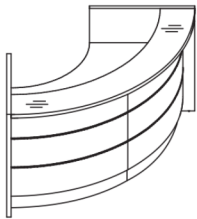

Symbol		Dimensions					kg m3 pcs	Composition elements
		W1	W2	D1	D2	H		
LAV53L		2317	1145	0	1307	1105	160.5 kg 1.15 m3 8 pcs	

Extra charge						
Monitor shelf x 1						
X						

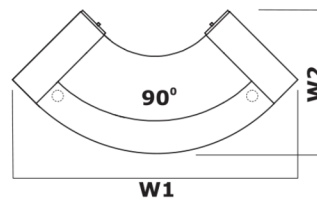
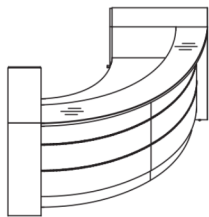

Symbol		Dimensions					kg m3 pcs	Composition elements
		W1	W2	D1	D2	H		
LAV73L		2713	1353	0	1307	1105	217.5 kg 1.798 m3 10 pcs	

Extra charge						
Monitor shelf x 1						
X						

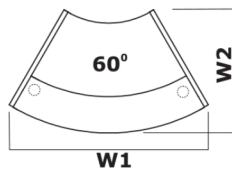
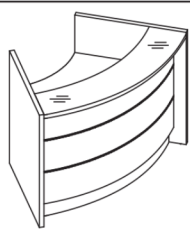

Symbol		Dimensions					kg m3 pcs	Composition elements
		W1	W2	D1	D2	H		
LAV54L		1666	1029	0	1307	1105	119.5 kg 0.779 m3 7 pcs	

Extra charge						
Monitor shelf x1						
X						

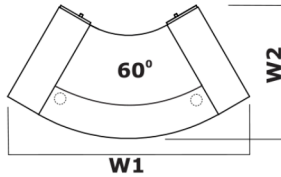
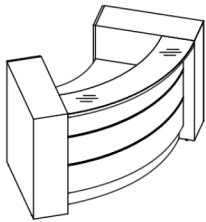

Symbol		Dimensions					kg m3 pcs	Composition elements
		W1	W2	D1	D2	H		
LAV74L		2151	1183	0	1307	1105	176.5 kg 1.427 m3 9 pcs	

Extra charge						
Monitor shelf x1						
X						

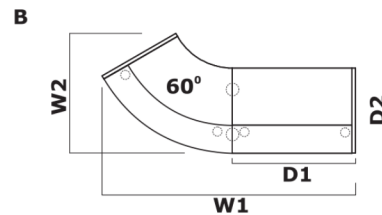
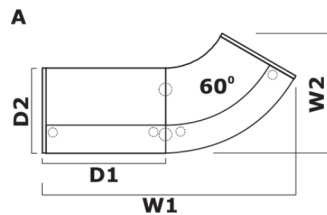
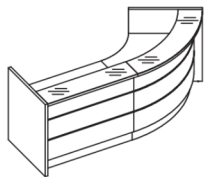

Symbol		Dimensions					kg m3 pcs	Composition elements
		W1	W2	D1	D2	H		
LAV78L	LAV79L	2733	1292	1328	917	1105	178.1 kg 1.071 m3 13 pcs	A - B -
LAV80L	LAV81L	3033	1292	1628	917	1105	191.5 kg 1.118 m3 13 pcs	A - B -
LAV82L	LAV83L	3733	1292	2318	917	1105	218 kg 1.242 m3 14 pcs	A - B -

Extra charge						
Monitor shelf x1	Monitor shelf x2					
X	X					
X	X					
X	X					

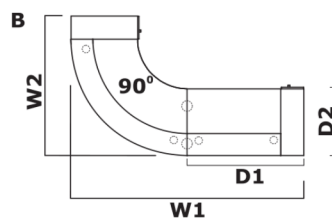
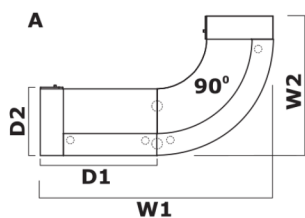
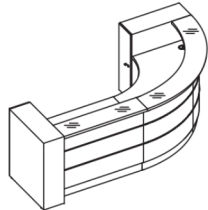

Symbol			Dimensions					kg m3 pcs	Composition elements
A	B		W1	W2	D1	D2	H		
LAV55L	LAV56L		3208	1918	1608	937	1105	276.1 kg 2.089 m3 16 pcs	A - B -
LAV57L	LAV58L		3508	1918	1908	937	1105	289.5 kg 2.137 m3 16 pcs	A - B -

Extra charge					
Monitor shelf x1	Monitor shelf x 2				
X	X				
X	X				

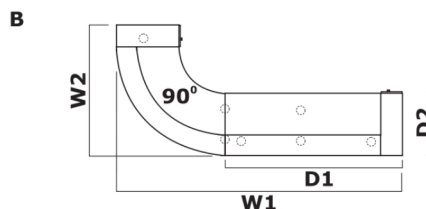
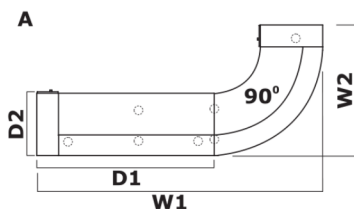
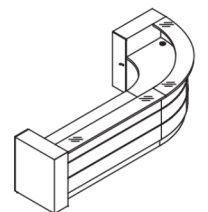

Symbol			Dimensions					kg m3 pcs	Composition elements
A	B		W1	W2	D1	D2	H		
LAV59L	LAV60L		4208	1918	2608	937	1105	316 kg 2.261 m3 17 pcs	A - B -

Extra charge					
Monitor shelf x1	Monitor shelf x 2				
X	X				

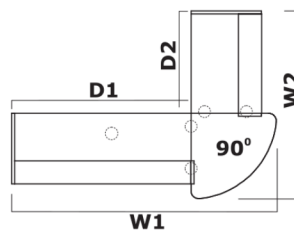
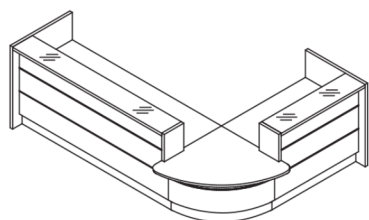

Symbol			Dimensions					kg m3 pcs	Composition elements
			W1	W2	D1	D2	H		
LAV107L			3437	2437	2318	1328	1105	244.2 kg 1.121 m3 18 pcs	
LAV108L			3437	2737	2318	1628	1105	257.6 kg 1.168 m3 18 pcs	
LAV109L			3437	3437	2318	2318	1105	284.1 kg 1.293 m3 19 pcs	

Extra charge					
Monitor shelf x1	Monitor shelf x 2				
X	X				
X	X				
X	X				

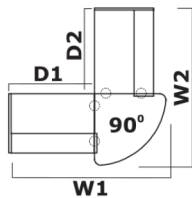
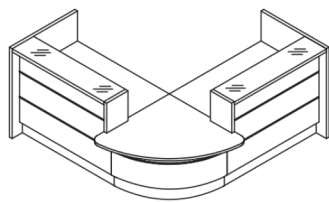

Symbol		Dimensions					kg m3 pcs	Composition elements
		W1	W2	D1	D2	H		
LAV101L		2437	2437	1328	1328	1105	204.3 kg 0.95 m3 17 pcs	
LAV102L		2437	2737	1328	1628	1105	217.7 kg 0.997 m3 17 pcs	
LAV103L		2437	3437	1328	2318	1105	244.2 kg 1.121 m3 18 pcs	
LAV104L		2737	2437	1628	1328	1105	217.7 kg 0.997 m3 17 pcs	
LAV105L		2737	2737	1628	1628	1105	231.1 kg 1.044 m3 17 pcs	
LAV106L		2737	3437	1628	2318	1105	257.6 kg 1.168 m3 18 pcs	

Extra charge					
Monitor shelf x1	Monitor shelf x 2				
X	X				
X	X				
X	X				
X	X				
X	X				
X	X				

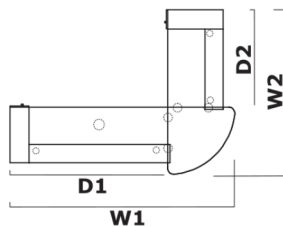
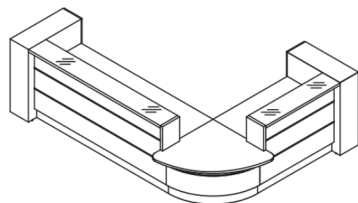

Symbol		Dimensions					kg m3 pcs	Composition elements
		W1	W2	D1	D2	H		
LAV122L		3717	2717	2608	1608	1105	301.2 kg 1.769 m3 20 pcs	
LAV123L		3717	3017	2608	1908	1105	314.6 kg 1.816 m3 20 pcs	
LAV124L		3717	3717	2608	2608	1105	341.1 kg 1.94 m3 21 pcs	

Extra charge					
Monitor shelf x1	Monitor shelf x 2				
X	X				
X	X				
X	X				

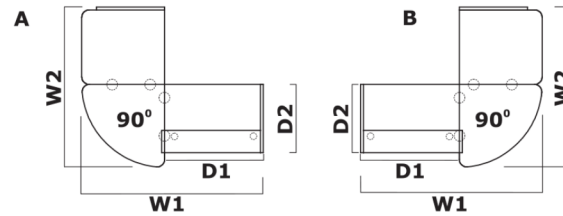
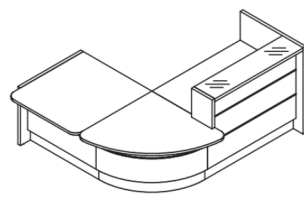

Symbol			Dimensions					kg m3 pcs	Composition elements
A	B		W1	W2	D1	D2	H		
LAV110L	LAV111L		2442	2147	1328	917	1105	176.4 kg 0.832 m3 16 pcs	A - B -
LAV112L	LAV113L		2742	2147	1628	917	1105	189.8 kg 0.879 m3 16 pcs	A - B -
LAV114L	LAV115L		3442	2147	2318	917	1105	216.3 kg 1.004 m3 17 pcs	A - B -
LAV1101L	LAV1111L		2442	1947	1328	917	1105	172.4 kg 0.809 m3 16 pcs	A - B -
LAV1121L	LAV1131L		2742	1947	1628	917	1105	185.8 kg 0.856 m3 16 pcs	A - B -
LAV1141L	LAV1151L		3442	1947	2318	917	1105	212.3 kg 0.98 m3 17 pcs	A - B -

Extra charge						
Monitor shelf x1						
X						
X						
X						
X						
X						
X						

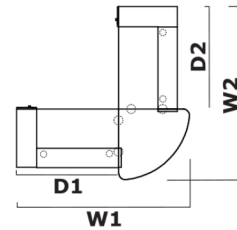
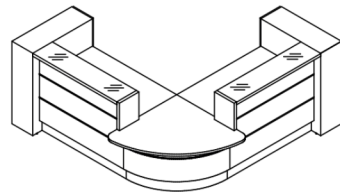

Symbol			Dimensions					kg m3 pcs	Composition elements
			W1	W2	D1	D2	H		
LAV116L			2717	2717	1608	1608	1105	261.3 kg 1.597 m3 19 pcs	
LAV117L			2717	3017	1608	1908	1105	274.7 kg 1.644 m3 19 pcs	
LAV118L			2717	3717	1608	2608	1105	301.2 kg 1.769 m3 20 pcs	
LAV119L			3017	2717	1908	1608	1105	274.7 kg 1.644 m3 19 pcs	

Extra charge						
Monitor shelf x1	Monitor shelf x2					
X	X					
X	X					
X	X					
X	X					

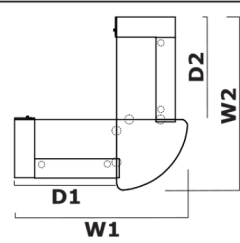
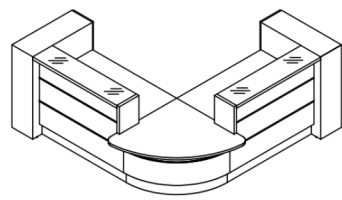

Symbol		Dimensions					kg m3 pcs	Composition elements
		W1	W2	D1	D2	H		
LAV120L		3017	3017	1908	1908	1105	288.1 kg 1.691 m3 19 pcs	
LAV121L		3017	3717	1908	2608	1105	314.6 kg 1.816 m3 20 pcs	

Extra charge					
Monitor shelf x 1	Monitor shelf x 2				
X	X				
X	X				

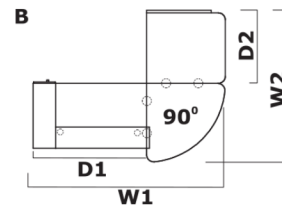
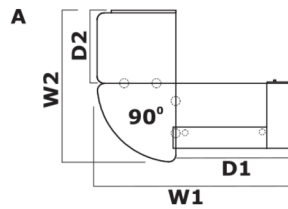
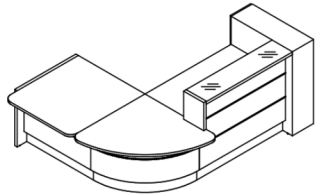

Symbol		Dimensions					kg m3 pcs	Composition elements
A	B	W1	W2	D1	D2	H		
LAV125L	LAV126L	2722	2147	1608	1038	1105	206.4 kg 1.162 m3 17 pcs	A - B -
LAV127L	LAV128L	3022	2147	1908	1038	1105	215.3 kg 1.198 m3 16 pcs	A - B -
LAV129L	LAV130L	3722	2147	2608	1038	1105	241.8 kg 1.322 m3 17 pcs	A - B -
LAV1251L	LAV1261L	2722	1947	1608	838	1105	202.4 kg 1.138 m3 17 pcs	A - B -
LAV1271L	LAV1281L	3022	1947	1908	838	1105	211.3 kg 1.175 m3 16 pcs	A - B -
LAV1291L	LAV1301L	3722	1947	2608	838	1105	237.8 kg 1.299 m3 17 pcs	A - B -

Extra charge					
Monitor shelf x 1					
X					
X					
X					
X					
X					

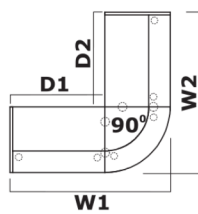
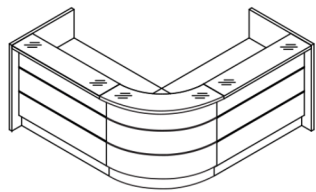

Symbol		Dimensions					kg m3 pcs	Composition elements
		W1	W2	D1	D2	H		
LAV131L		2245	2245	1328	1328	1105	206.7 kg 1.036 m3 16 pcs	
LAV132L		2245	2545	1328	1628	1105	220.1 kg 1.083 m3 16 pcs	
LAV133L		2245	3245	1328	2318	1105	246.6 kg 1.208 m3 17 pcs	

Extra charge					
Monitor shelf x1	Monitor shelf x 2				
X	X				
X	X				
X	X				

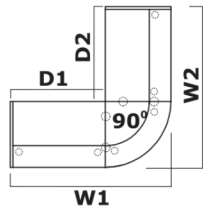
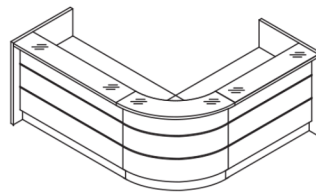

Symbol		Dimensions					kg m3 pcs	Composition elements
		W1	W2	D1	D2	H		
LAV134L		2545	2245	1628	1328	1105	220.1 kg 1.083 m3 16 pcs	
LAV135L		2545	2545	1628	1628	1105	233.5 kg 1.13 m3 16 pcs	
LAV136L		2545	3245	1628	2318	1105	260 kg 1.255 m3 17 pcs	

Extra charge					
Monitor shelf x1	Monitor shelf x 2				
X	X				
X	X				
X	X				

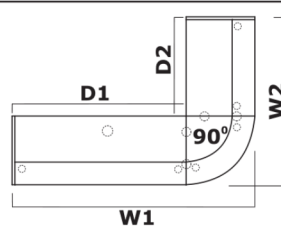
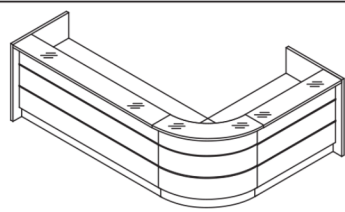

Symbol		Dimensions					kg m3 pcs	Composition elements
		W1	W2	D1	D2	H		
LAV137L		3245	2245	2318	1328	1105	246.6 kg 1.208 m3 17 pcs	
LAV138L		3245	2545	2318	1628	1105	260 kg 1.255 m3 17 pcs	
LAV139L		3245	3245	2318	2318	1105	286.5 kg 1.379 m3 18 pcs	

Extra charge						
Monitor shelf x1	Monitor shelf x 2					
X	X					
X	X					
X	X					

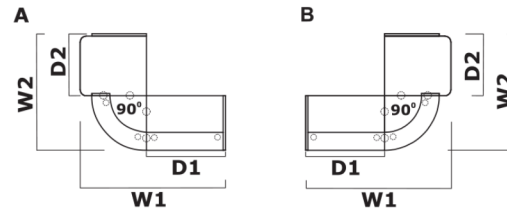
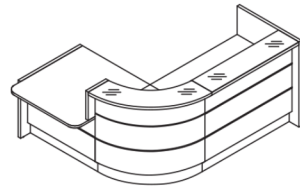

Symbol		Dimensions					kg m3 pcs	Composition elements
		W1	W2	D1	D2	H		
A	B							
LAV140L	LAV141L	2442	1955	1328	1038	1105	184.4 kg 0.933 m3 17 pcs	A - B -
LAV142L	LAV143L	2742	1955	1628	1038	1105	197.8 kg 0.98 m3 17 pcs	A - B -
LAV1401L	LAV1411L	2442	1755	1328	838	1105	180.4 kg 0.91 m3 17 pcs	A - B -
LAV1421L	LAV1431L	2742	1755	1628	838	1105	193.8 kg 0.957 m3 17 pcs	A - B -

Extra charge						
Monitor shelf x1						
X						
X						
X						
X						

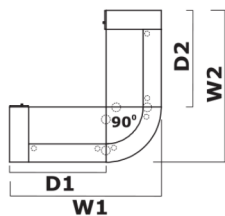
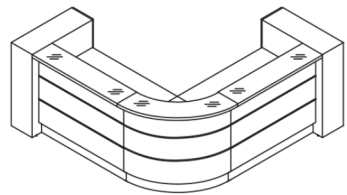

Symbol		Dimensions					kg m3 pcs	Composition elements
		W1	W2	D1	D2	H		
LAV146L		2525	2525	1608	1608	1105	263.7 kg 1.684 m3 18 pcs	
LAV147L		2525	2825	1608	1908	1105	277.1 kg 1.731 m3 18 pcs	
LAV148L		2525	3525	1608	2608	1105	303.6 kg 1.855 m3 19 pcs	
LAV149L		2825	2525	1908	1608	1105	277.1 kg 1.731 m3 18 pcs	
LAV150L		2825	2825	1908	1908	1105	290.5 kg 1.778 m3 18 pcs	
LAV151L		2825	3525	1908	2608	1105	317 kg 1.902 m3 19 pcs	

Extra charge					
Monitor shelf x1	Monitor shelf x 2				
X	X				
X	X				
X	X				
X	X				
X	X				
X	X				

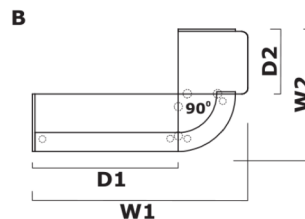
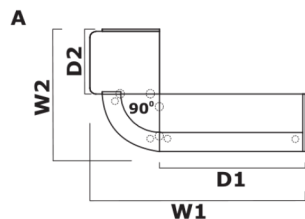
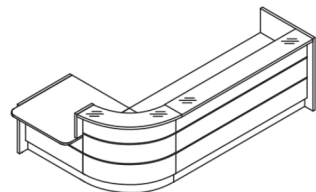

Symbol		Dimensions					kg m3 pcs	Composition elements
		W1	W2	D1	D2	H		
LAV144L	LAV145L	3442	1955	2318	1038	1105	224.3 kg 1.104 m3 18 pcs	A - B -
LAV1441L	LAV1451L	3442	1755	2318	838	1105	220.3 kg 1.081 m3 18 pcs	A - B -

Extra charge					
Monitor shelf x1					
X					
X					

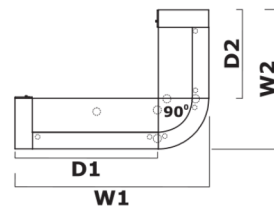
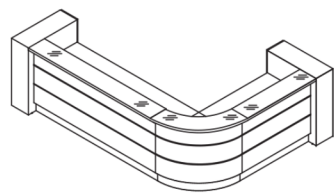

Symbol		Dimensions					kg m3 pcs	Composition elements
		W1	W2	D1	D2	H		
LAV152L		3525	2525	2608	1608	1105	303.6 kg 1.855 m3 19 pcs	
LAV153L		3525	2825	2608	1908	1105	317 kg 1.902 m3 19 pcs	
LAV154L		3525	3525	2608	2608	1105	343.5 kg 2.027 m3 20 pcs	

Extra charge					
Monitor shelf x 1	Monitor shelf x 2				
X	X				
X	X				
X	X				

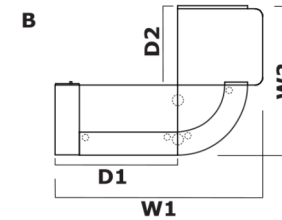
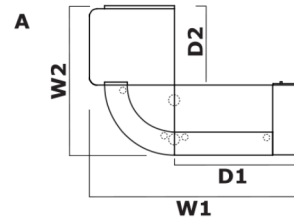
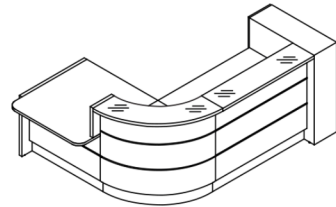

Symbol		Dimensions					kg m3 pcs	Composition elements
		W1	W2	D1	D2	H		
LAV155L	LAV156L	2722	1955	1608	1038	1105	209.9 kg 1.251 m3 17 pcs	A - B -
LAV157L	LAV158L	3022	1955	1908	1038	1105	223.3 kg 1.299 m3 17 pcs	A - B -
LAV159L	LAV160L	3722	1955	2608	1038	1105	249.8 kg 1.423 m3 18 pcs	A - B -
LAV1551L	LAV1561L	2722	1755	1608	838	1105	205.9 kg 1.228 m3 17 pcs	A - B -
LAV1571L	LAV1581L	3022	1755	1908	838	1105	219.3 kg 1.275 m3 17 pcs	A - B -
LAV1591L	LAV1601L	3722	1755	2608	838	1105	245.8 kg 1.4 m3 18 pcs	A - B -

Extra charge					
Monitor shelf x 1					
X					
X					
X					
X					
X					

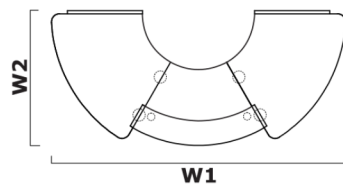
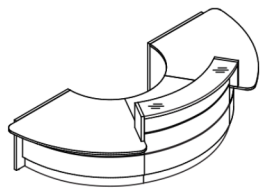

Symbol		Dimensions					kg m3 pcs	Composition elements
A	B	W1	W2	D1	D2	H		
LAV05L		3589	1629	2608	838	1105	224.1 kg 1.781 m3 17 pcs	

Extra charge						
Monitor shelf x1						
X						

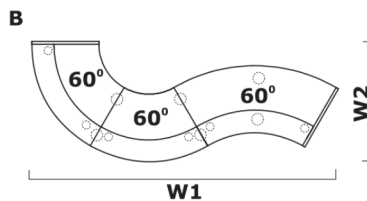
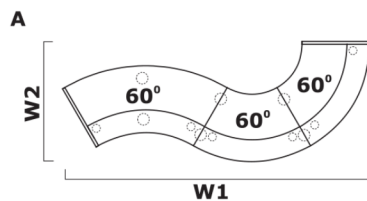
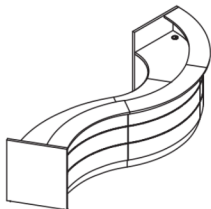

Symbol		Dimensions					kg m3 pcs	Composition elements
A	B	W1	W2	D1	D2	H		
LAV06L	LAV07L	4199	1629	2608	838	1105	269.5 kg 2.345 m3 20 pcs	A - B -

Extra charge						
Monitor shelf x1	Monitor shelf x2	Monitor shelf x3				
X	X	X				

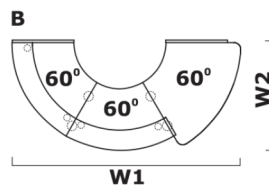
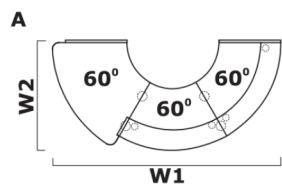
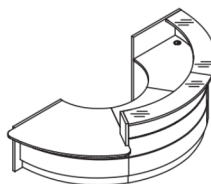

Symbol		Dimensions					kg m3 pcs	Composition elements
A	B	W1	W2	D1	D2	H		
LAV08L	LAV09L	3367	1629	2608	838	1105	235.3 kg 2.009 m3 16 pcs	A - B -

Extra charge						
Monitor shelf x1	Monitor shelf x2					
X	X					

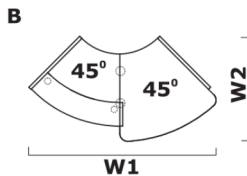
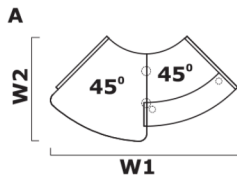
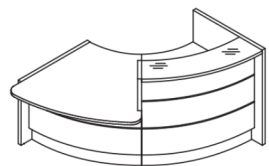

Symbol			Dimensions					kg m3 pcs	Composition elements
A	B		W1	W2	D1	D2	H		
LAV161L	LAV162L		2320	1114	2608	838	1105	138.8 kg 0.95 m3 11 pcs	A - B -

Extra charge					

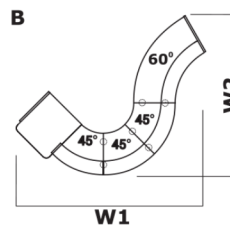
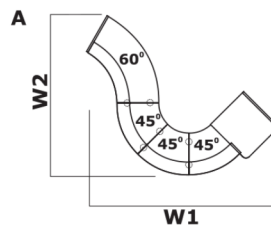

Symbol			Dimensions					kg m3 pcs	Composition elements
A	B		W1	W2	D1	D2	H		
LAV163L	LAV164L		4080	3540	2608	838	1105	325.3 kg 2.675 m3 27 pcs	A - B -
LAV1631L	LAV1641L		4080	3540	2608	838	1105	321.3 kg 2.651 m3 27 pcs	A - B -

Extra charge					
Monitor shelf x1					
X					
X					

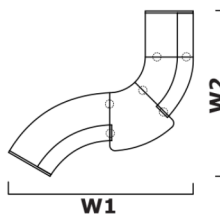
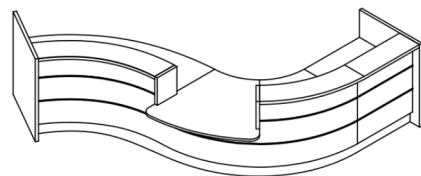

Symbol			Dimensions					kg m3 pcs	Composition elements
			W1	W2	D1	D2	H		
LAV165L			2677	3946	2608	838	1105	297.1 kg 2.069 m3 25 pcs	

Extra charge					
Monitor shelf x1					
X					

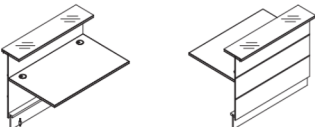
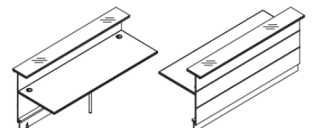
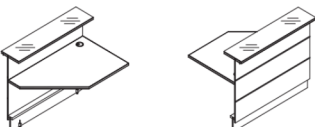
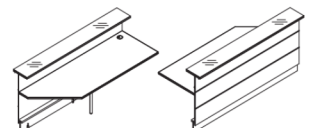
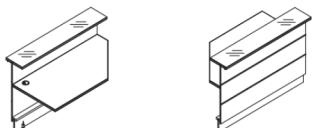
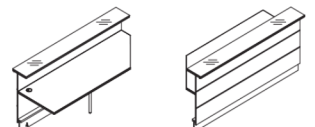
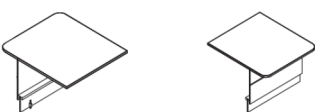
Straight elements							
	Symbol	Dimensions			kg m3 pcs	Comments	
		Width	Depth	Height			
	LA09L	844	917	1105	36 kg 0.149 m3 4 pcs		
	LA13L	1290	917	1105	53.6 kg 0.223 m3 4 pcs		
	LA16L	1590	917	1105	67 kg 0.27 m3 4 pcs		
	LA23L	2290	917	1105	93.5 kg 0.395 m3 5 pcs		
	LAP13L	1290	917	1105	52.6 kg 0.223 m3 4 pcs		
	LAP16L	1590	917	1105	66.5 kg 0.27 m3 4 pcs		
	LAP23L	2290	917	1105	93 kg 0.395 m3 5 pcs		
	LAL13L	1290	917	1105	52.6 kg 0.223 m3 4 pcs		
	LAL16L	1590	917	1105	66.5 kg 0.27 m3 4 pcs		
	LAL23L	2290	917	1105	93 kg 0.395 m3 5 pcs		
	LAU11L	1000	1114	740	32.5 kg 0.123 m3 3 pcs		
	LAU18L	800	1114	740	28.5 kg 0.1 m3 3 pcs		

Extra charge						
Monitor shelf x1	Monitor shelf x 2					
X						
X						
X						
X						
X						
X						
	X					

